

Optimization of Multi-band Rectangular-Triangular Slotted Antenna

¹K.swetha, ²K.Satish Kumar, ²B.Manoj Kumar reddy

¹Research Scholar, Department of ECE, A. P, India

²Project Students, Department of E.C.E, Vignan University, A. P, India

ABSTRACT

A multi-band microstrip patch antenna is developed and presented in this paper. The radiating elements in this antenna are composed of rectangular and triangular slots. These slots are engraved in the rectangular and triangular patch, joined together in one structure, and by single probe feed. The rectangular and triangular slots make the antenna to operate at multiband with relatively high gain. Therefore, this antenna can be used for wireless communication applications like WLAN, WiMax and radar system applications.

Key Words: Microstrip antennas, WiMax, WLAN.

I. INTRODUCTION

The design of an efficient wideband small size antenna for recent wireless applications is a major challenge. The microstrip patch antenna have found extensive applications in wireless communication systems owing to their advantages such as low profile, conformability, low fabrication cost and ease of integration with feed network. Microstrip patch antennas comes with drawback of narrow bandwidth, but wireless communication applications require broad bandwidth and relative high gain in order to achieve that we need to increase the substrate thickness, use of low dielectric substrates and various impedance matching feeding techniques and slotting techniques.

The concept of inserting slot array following a chebyshev distribution has proven to give remarkable functionality to an antenna [1]. It causes it to radiate significantly at different ranges of frequencies by using only one single feed point. But, it operates at less number of bands. A rectangle added to an equilateral triangle patch which is fed by a probe has a dual-band operation. With the rapid development of the wireless communication, the tri-band even multi-band antennas are needed to meet the requirement. Stacked microstrip antenna can achieve multi-band circular polarization (CP) radiation more easily than conventional antennas. Generally the stacked microstrip antennas can easily achieve dual-band operation [2]. But the limitations of the stacked microstrip antenna are the size, fabrication complexity, and cost.

In this paper, a single-feed multi-band microstrip patch antenna for wireless communication applications is presented. The multi-band is achieved by the patch, which represents a combination of a rectangular and an isosceles-triangular patch. The part of the patch formed by the isosceles triangle has the same area as the part formed by the rectangle. The rectangular slots

are inserted into the rectangular part, and the triangular slots are inserted into the isosceles-triangular part of the patch. The whole system is fed by a coaxial probe into the substrate, with an input impedance of 50 Ω .

II. ANTENNA DESIGN

The basic structure of the proposed antenna, shown in Figure 1, consists of 3 layers. The lower layer constitutes of ground plane covered by the substrate having a width of 6 cm and a length of 15 cm. The middle layer is the substrate which has a dielectric constant $\epsilon_r = 2.2$ and a height of 0.32 cm. The upper layer, which is the patch, consists of a rectangle with a length of 4 cm and a width of 3 cm, joined with an isosceles triangle having the same area as the rectangular patch and a base of 3 cm and a height of 8 cm.

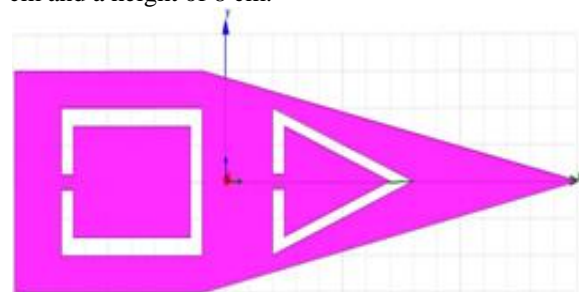

Fig 1: Proposed Patch Structure

Inside the rectangular patch, two rectangular slots were inserted, one with a length of 3 cm and a width of 2 cm and the other with a length of 2.5 cm and a width of 1.5 cm. Also, inside the triangular patch, two triangular slots were inserted, one with a base of 2 cm and a height of 3 cm and the other with a base of 2.5 cm and a height of 2.25 cm. Stubs were used in order to join the rectangular and

triangular slots with a length of 0.25 cm and a width of 0.2 cm. Placing of slots into the structure increases the beamwidth and increase resonances.

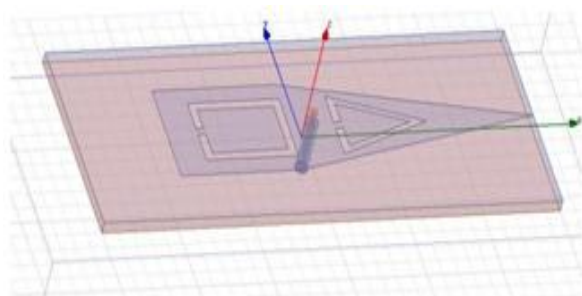

Fig 2: Antenna model

A parametric study and an optimization were done, in order to find the best feeding point of the structure. Several points were tested in order to get an overview of the defined functioning of the antenna, and to monitor the effect of both the rectangular and triangular slots. Figure 2 shows the proposed antenna on Rogers RT/ Duroid 5880 (tm). At first, the feeding point is chosen near the edge of the rectangle on its right-hand side. Results showed the operation of the antenna at less number of bands and also with low gain since the feeding point is bit far from the triangular slot where the multi-band operation is triggered. The feeding point is moved close to the radiating elements, in order to obtain optimum operation of the antenna. When the feeding point is closer to the triangular slot, the functioning of the antenna is more effective with relatively high gain.

III. RESULTS

A. Return Losses

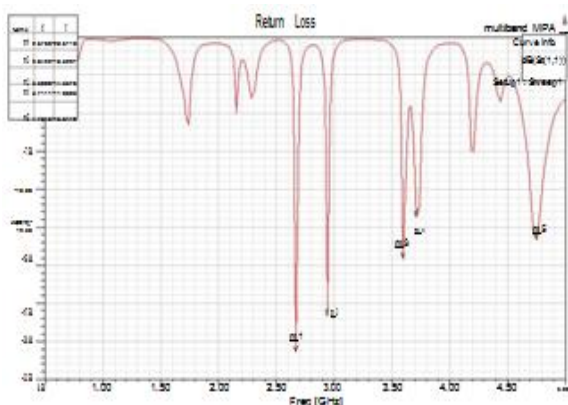

Fig 3: Return loss

From Figure 3, the return losses of the proposed antenna at 2.67 GHz, 2.94 GHz, 3.59 GHz, 3.71 GHz and 4.75 GHz are -20.67 dB, -18.32 dB, -14.55 dB, -11.80 dB and -13.31 dB respectively.

B. Gain

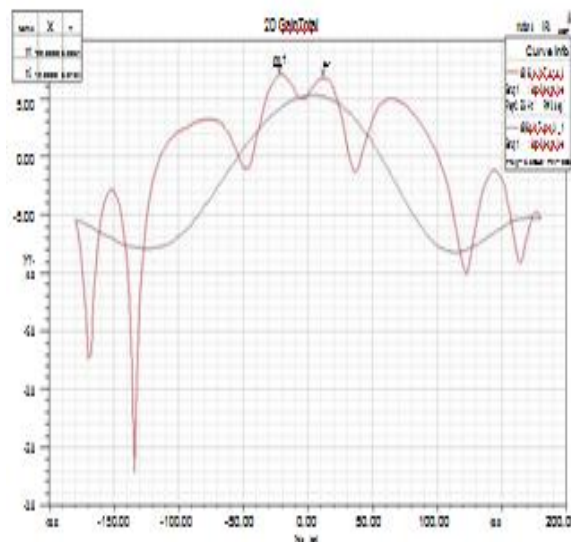

Fig 4: 2D- Gain Total

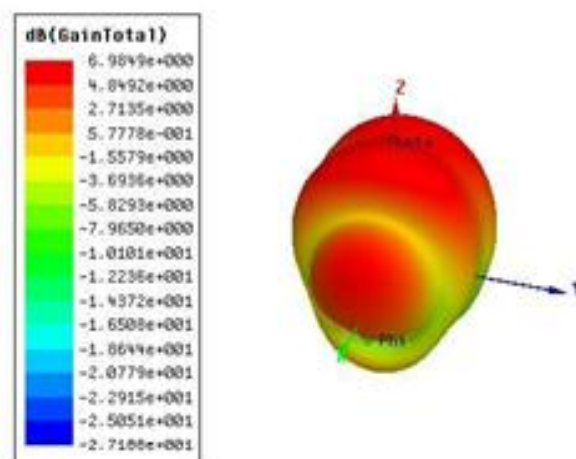

Fig 5: 3D- Gain Total

Figure 4 and Figure 5 shows the gain of the antenna in 2D and 3D patterns. The gain of the proposed antenna is 6.9831 dB.

C. Radiation Patterns

The far electric fields of the rectangular patch are as follows

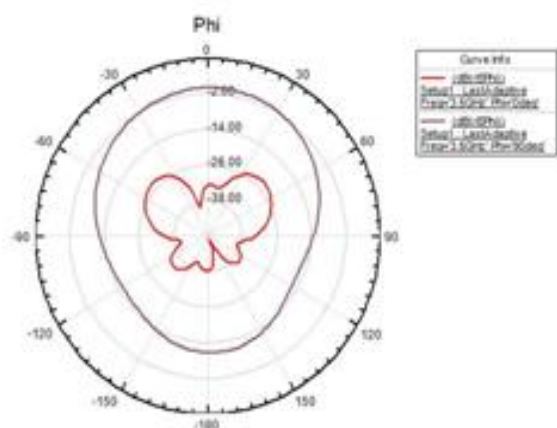

Fig 6: Gain along Phi

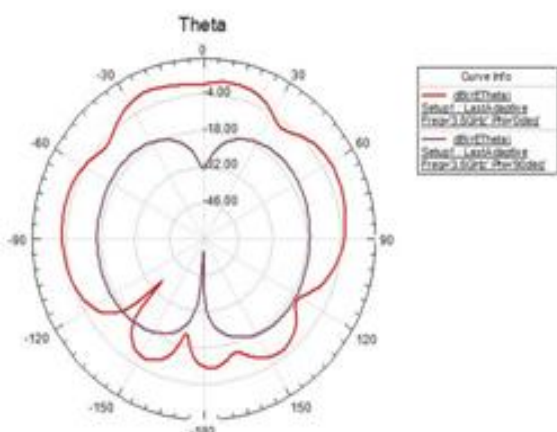

Fig 7: Gain along Theta

The radiation pattern for the proposed antenna for Phi and Theta at 0 deg and 90 deg is shown in the Figure 6 and Figure 7.

D. Field Distributions

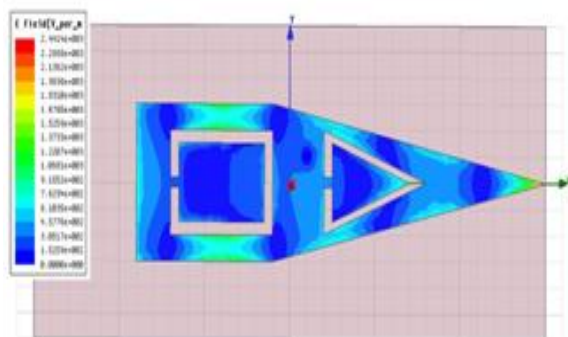

Fig 8: E-field Distributions

The effect produced by an electric charge that exerts a force on charged objects is the E-field and its distribution in the patch is as shown in the Figure 8.

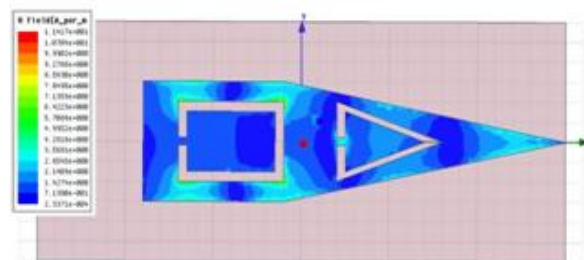

Fig 9: H-field Distributions

The measured intensity of a magnetic field in the patch is shown in Figure 9.

E. Current Distribution

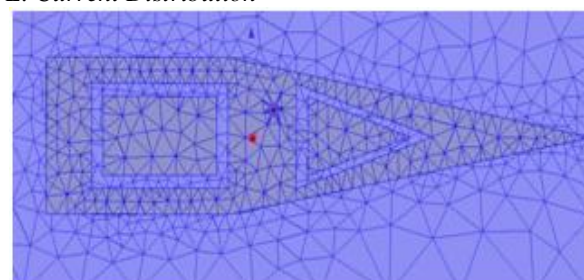

Fig 10: Mesh Plot

Figure 10 shows the current distribution on the patch and from the figure it is clear that current distribution is more on the patch when compared to the substrate.

IV. CONCLUSION

From the analysis of multi-band rectangular-triangular slotted patch antenna on Rogers RT/Duroid 5880 (tm) substrate exhibits broadband resonance with relatively high gain. Thus, this model is well suitable for various S-band applications like wireless CCTV and wireless video links, WLAN applications (2.8 GHz), WLAN, WiMax, wireless WiMax, 802.11a applications (3.5 GHz) and also suitable for radar system applications (4.75 GHz). The antenna is successfully designed and optimized. The results show that the antenna not only has multi-band characteristic but also have good radiation patterns.

V. ACKNOWLEDGMENT

The authors would like to thank the management of VIGNAN University, Vijayawada for excellent encouragement during the tenure of work.

REFERENCES

[1] J Costantine, K Y. Kabalan, Ali El-Hajj, and Mohammad Rammal, "A New Multi-band Microstrip Antenna Design for Wireless Communications", *IEEE Transactions on Antennas and*

- Propagation Magazine, Vol. 49, No. 6, Dec 2007.
- [2] Wen Liao, Qing-Xin Chu and Shu Du, "Tri-band Circularly Polarized Stacked Microstrip Antenna for GPS and CNSS Applications", *IEEE Transactions*, 2010.
- [3] W. S. Chen and F. M. Hsieh, "A Broadband Design for a Printed Isosceles Triangular Slot Antenna for Wireless Communications", *Microwave Journal*, 48, 7, July 2005, pp. 98-112.
- [4] C. A. Balanis, *Antenna Theory Analysis and Design, Second Edition*, New York, Wiley, 1997.
- [5] J. Constantine, *New Multi Band Design for a Microstrip Patch Antenna* Masters thesis, American University of Beirut, October 2006.
- [6] Kin-Lu Wong, *Compact and Broadband Microstrip Antennas*, A Wiley-Interscience Publication, 2002.
- [7] Jawad K. Ali, "A New Compact Size Microstrip Patch Antenna with Irregular Slots for Handheld GPS Application", *Eng. & Technology*, Vol. 26, No. 10, 2008.
- [8] Neenasha Jain, Anubhuti Khare, Rajesh Nema, "E-Shape Microstrip Patch Antenna on Different Thickness for pervasive Wireless Communication", *International Journal of Advanced Computer Science and Applications*, Vol. 2, No. 4, 2011.
- [9] Nishamol M. S., Aanandan C. K., Mohanan P. and Vasudevan K., "Dual Frequency Reconfigurable Microstrip Antenna using Varactor Diodes", *IEEE Transactions*, 2011.
- [10] Salman Haider, "Microstrip Patch Antennas for Broadband Indoor Wireless Systems", 2003.
- [11] T. Sittironnarit and M. Ali, "Analysis and Design of a Dual-Band Folded Microstrip Patch Antenna for Handheld Device Application", *IEEE Southeast Conference Proceedings*, 2002, pp. 255-258.
- [12] P. A. Ambresh, P. M. Hadalgi, "Experimental Results of Compact Dual Frequency Microstrip Slot Antenna", *IJECT* Vol. 2, Issue 3, Sept. 2011.
- [13] David M. Pozar and Sean M. Duffy, "A Dual-Band Circularly Polarized Aperture-Coupled Stacked Microstrip Antenna for Global Positioning Satellite", *IEEE Transactions on Antennas and Propagation*, Vol. 45, No. 11, November 1997.
- [14] Raj Kumar, Nivedita Mishra, "On the Design of Square-Cut Circular Multiband Antenna for Wireless Communication", 2nd International Conference and workshop on

Emerging Trends in Technology (ICWET)2011 Proceedings published by International Journal of Computer Applications (IJCA).

- [15] S. Hebib, H. Aubert, O. Pascal, N. Fonseca, L. Ries and J. M. Lopez, "Pyramidal multi-band antennas for GPS/Galileo/MicroSat Application", *IEEE* 2007.
- [16] Vinod K. Singh, Zakir Ali, "Dual Band U-Shaped Microstrip Antenna for Wireless Communication", Vol. 2(6), ISSN, 2010.

AUTHORS BIOGRAPHY



Kambhampati Swetha. Completed B.tech in Nimra College of Engineering, affiliated to JNTU Kakinada. Received Masters degree from the K.L.University. Area of Interests: Micro strip Patch Antennas, Wireless Communications And Satellite Communications.



K.Satish Kumar was born in ANDHRA PRADESH,INDIA.Completed B.tech in Sri venkateswara college of engineering and technology affiliated to Anna University 2011.Received masters degree from Vignan University in 2014.Area of Interests:Embedded systems, Antennas & Communications



B.Manoj Kumar Reddy was born in ANDHRA PRADESH, INDIA.Completed B.tech in St.Ann's college of engineering and technology affiliated to JNTU University 2012.Received masters degree from Vignan University in 2014.Area of interests: Embedded systems, Antennas & Communications